

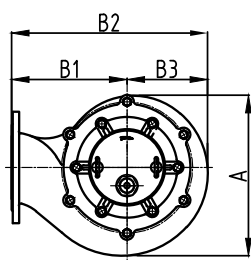

MWQ 3000-7500

Pompy z Agitatorem
– systemem
wymuszającym
wymieszanie osadu

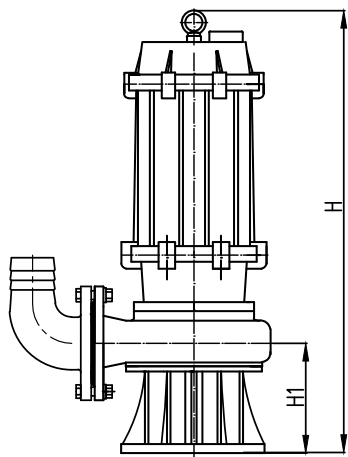

Model	Wymiary (mm)					
	H	H1	A	B1	B2	B3
MWQ 50/1100	471	104	187	190	230	137
MWQ 50/1500	491	117	208	230	238	143
MWQ 80/2200	551 / 544	128	230	230	278	167
MWQ 50/3000	556 / 559	120	215	230	258	151
MWQ 80/3000	559 / 562	122	220	230	260	152
MWQ 100/5500	660	146	258	260	310	180
MWQ 150/7500	730	175	300	320	330	198

↑ Podnoszenie / Wydajność
H
(m)

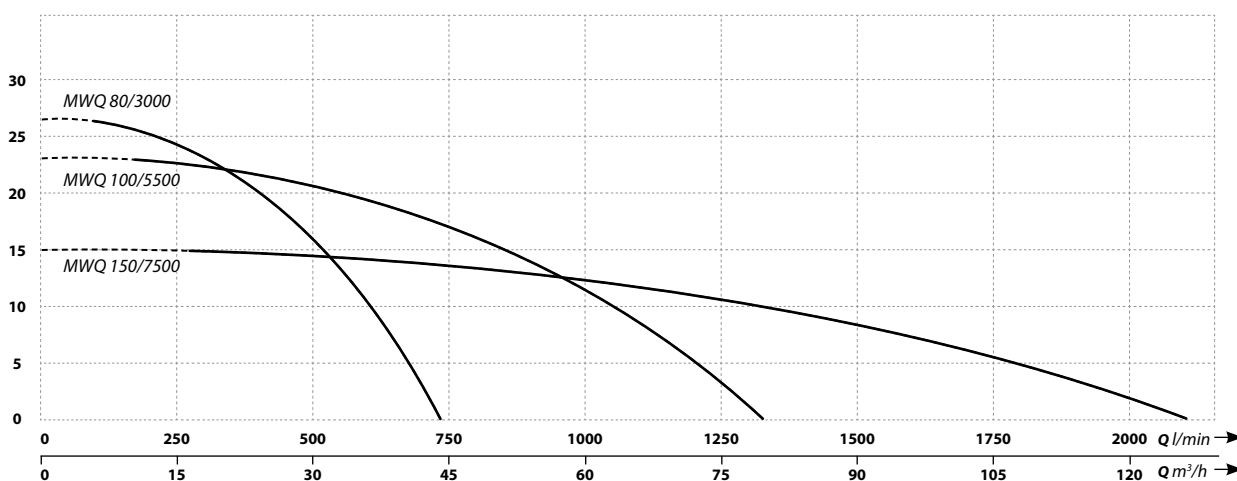

Model	Podnoszenie (m)	Wydajność (l/min)	Moc silnika (W)	Zasilanie (V)	Pobór prądu (A)	Średnica oddziaływania agitatora (mm)	Króciec (DN)	Waga (kg)
MWQ 80/3000	26,5	740	3000	400	6,1	1600	80	43
MWQ 100/5500	23	1320	5500	400	9,5	2000	100	76,5
MWQ 150/7500	15	2100	7500	400	15,4	2500	150	105